



**HI-G® DRYER  
FINES RECOVERY  
SYSTEM**

## DERRICK FINE SCREENING AND FINES RECOVERY TECHNOLOGY

The generation of fine solids are by far the largest concern within the industry. The Derrick HI-G® Dryer provides the most cost effective solution to handling these fines. This proven technology consists of a Derrick high G-force linear motion vibratory screen and a radial design cluster of Derrick 4 inch unibody hydrocyclones.

Since its inception in 1951, Derrick Corporation has been committed to provide the most advanced high frequency screening and solids control technology available throughout the world. Derrick Corporation, based in Buffalo, New York, U.S.A., is a fully integrated manufacturing facility supplying the aggregate industry with a high performance fines recovery system. From rugged, dependable dewatering equipment to our patented urethane and steel screen surfaces, our advancements are proven successful and continue to lead the way for the aggregate industry.

The Derrick Fines Recovery System consists of a cluster of 4 inch unibody hydrocyclones mounted over a HI-G Dryer, high G-force linear motion screening unit. This combination provides the industry with unmatched performance and dependability.

### SYSTEM OPERATION

The Derrick 4 inch hydrocyclones are mounted on a radial design manifold, which is fed the wash plant discharge under a consistent pressure of 35 to 37 psi. The centrifugal separation extracts the ultra fine sands and silts discharging them out the underflow. The fines are leaving the hydrocyclone at approximately 55 to 60% solids where they are fed to our high G-force dewatering screen.

The Derrick HI-G Dryer dewatering unit is outfitted with two 2.5 hp electromechanical vibrators that operate at 1,750 rpm with a stroke length of 0.19 inches. The combination of stroke length and rotation speed create 7.3 G's of acceleration on the screen surface, resulting in efficient separation of water from the fine solids. The dewatered fine solids are then discharged from the screening machine at 75 to 80% solids.

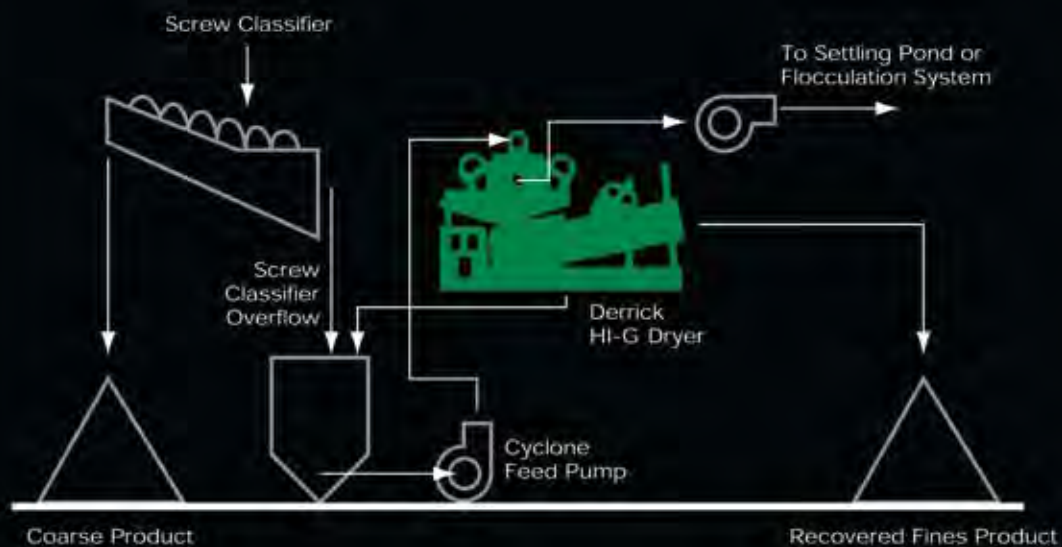

The Derrick HI-G Dryer Fines Recovery System provides the aggregate industry with unparalleled performance and unmatched cost effectiveness in handling by-product fines.

- Recover up to 80% of the solids currently reporting to your settling pond facility.
- Recover ultra sands and silts.
- Greatly reduce pond cleaning efforts.
- Increase the life of your current settling pond facility.
- Drastically reduce maintenance costs involved with cleaning settling ponds.
- All recovered solids are provided in a consistently stackable and conveyable form at 75 to 80% solids.
- Turn a once wasted material into a marketable product.
- No costly polymers, flocculants or chemicals needed.

#### HYDROCYCLONES



The 4 inch hydrocyclones are mounted on our radial designed manifold. This provides each hydrocyclone with the same amount of water, solids and pressure to assure the most efficient separation possible. Each hydrocyclone is outfitted with a ceramic lined thread in the cone tip, as well as an individual shut-off valve.

#### URETHANE SCREENS

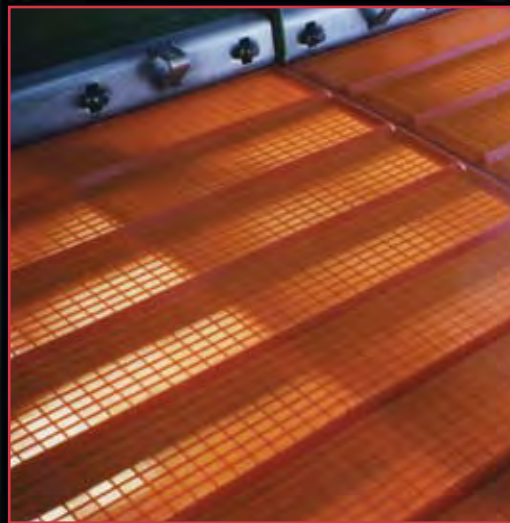

While urethane screen surfaces are known for their abrasion resistance, only Derrick's patented urethane screen surfaces combine long life with high open area and capacity. Moreover, its anti-blinding properties allow for uninterrupted performance with minimized operator requirements.

## HI-G DRYER FINES RECOVERY SYSTEM INSTALLATIONS



Palette Stone, NY - Recovered solids are conveyed to a stock pile where they are sold as product.



Minnesota Producers - Advanced urethane and ceramic technology provide superior life even in high silica recoveries.



Tri-City Materials - Canadian producers are experiencing major savings with the HI-G Dryer.



P.J. Keating Materials, MA - Recovered solids are more cost effectively handled with a pay-loader as opposed to drag lining solids or harvesting by excavator in a "soupy" form.



Hybanks Gravel, NY - Drastically reducing pond cleaning frequencies.



Keystone Quarries, PA - Systems can be custom designed to accommodate any flow and solids rates.

## **DERRICK HI-G® DRYER FINES RECOVERY SYSTEM**

Derrick HI-G Dryer complete turnkey package includes a custom designed two chambered sump arrangement, sand slurry pump as well as all plumbing and electrical requirements. Convenient stairway and cat walk arrangements provide easy access to all equipment.



### **DESIGNS FOR YOUR SPECIFIC NEEDS**

Derrick Applications Engineers work directly with you to determine the screening system best suited for your application. All project details are analyzed to provide the most economical equipment recommendations.

Whether purchasing a complete solids control system or individual screening unit, Derrick's commitment to providing complete customer satisfaction is second to none.

- Complete Turnkey Packages
- Individual HI-G Dryer Fine Recovery Units
- Unit Support/Stand Structures
- Complete On-Site Test/Demonstration Unit Available

## SCREENING MACHINES — SPECIALLY DESIGNED, CUSTOM BUILT

Below are several examples of screening equipment offered to the solids control end user. These examples are intended to simply illustrate the range of equipment types. Derrick's modern, fully integrated manufacturing facility allows flexibility in the construction of these machines and we look forward to working with each customer to match a screening unit design to their particular needs.

HI-G DRYER DIMENSIONS:	<b>Height:</b>	116 11/16"	(2964 mm)
	<b>Width:</b>	70 1/8"	(1781 mm)
	<b>Length:</b>	114"	(2896 mm)
	<b>Weight:</b>	6,500 lbs	(2749 kg)

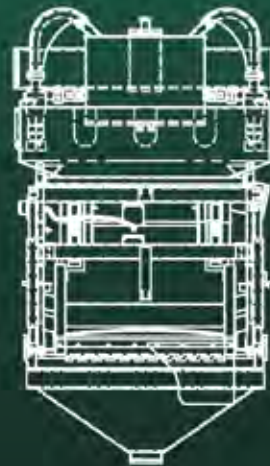
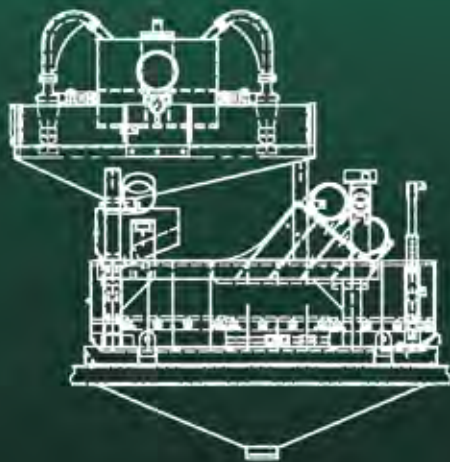

TANK SYSTEM DIMENSIONS:	<b>Height:</b>	207 1/2"	(5271 mm)
	<b>Width:</b>	206 15/16"	(5256 mm)
	<b>Length:</b>	189 3/8"	(4810 mm)
	<b>Weight:</b>	19,800 lbs	(8989 kg)

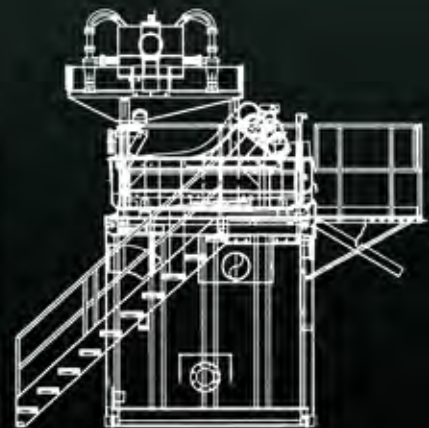
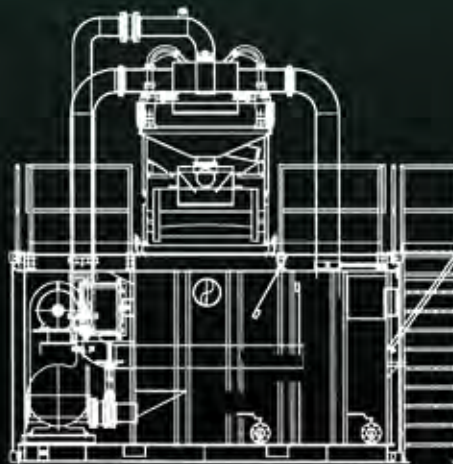
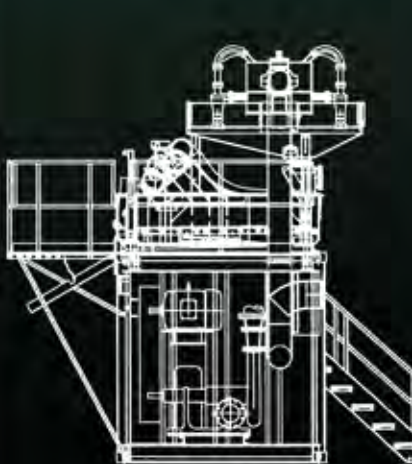

590 Duke Road • Buffalo, New York 14225  
Phone: (716) 683-9010 • Fax: (716) 683-4991  
E-mail: [info@derrickcorp.com](mailto:info@derrickcorp.com) • [www.DerrickCorp.com](http://www.DerrickCorp.com)